

TROLLEYS

Trolleys BOK I

for light loads
max. 250 kg

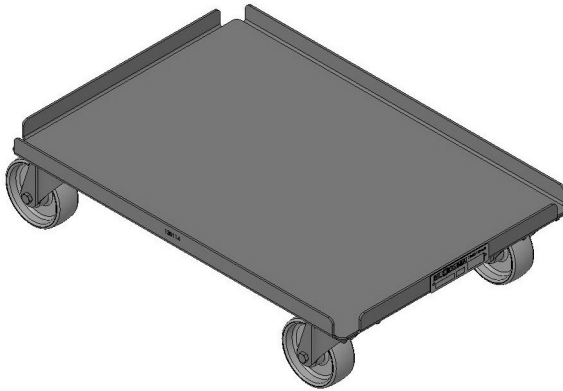

Item no. 129928

For indoor transport of a stack of boxes

Various wheel qualities (PP, rubber or PU-coated or ESD)

Designed for various boxes / containers (workpiece carriers, boxes, wire baskets or similar)

Various material available (steel, stainless steel, aluminium)

Optional products can be found in chapter ACCESSORIES

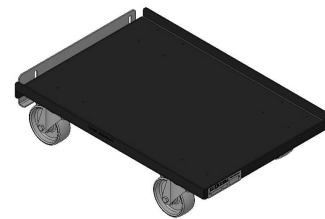
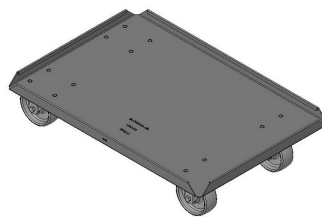

Item no.	Product to be carried	Size of trolley and load	Centering of product	Wheels	Wheel design
129928	Box 600 x 400 mm	610 x 420 mm 250 kg	on inside edge of the frame	Ø 100 mm PA	4 swivel castors
134138	Box 600 x 400 mm	610 x 420 mm 250 kg	on inside edge of the frame with crane hook	Ø 100 mm rubber	4 swivel castors
134194	Box 600 x 400 mm	620 x 420 mm 250 kg	on inside edge of the frame	Ø 100 mm PA	4 swivel castors
136997	Box 600 x 400 mm	620 x 420 mm 250 kg	on inside edge of the frame	Ø 100 mm ESD	4 swivel castors
139205	Box 600 x 400 mm	610 x 420 mm 250 kg	on inside edge of the frame one side can be opened	Ø 100 mm PA	4 swivel castors
130520	Box 800 x 600 mm	830 x 630 mm 250 kg	on inside edge of the frame	Ø 100 mm PA	4 swivel castors

Other models / dimensions on request.